

N. A. Artamonov, B. F. Abrosimov, and
M. Z. Maksimenko

UDC 533.6.01:536.7

The results of experimental studies of the pressure gradient field near the axis are presented, and the change in the pitch of the screw structure of gas flows is determined.

Different devices based on a vortex tube are widely used for cooling gases and removing a liquid phase and dust from them. Vortex shell-and-tube heat exchangers with a spiral swirling unit (SSU) are employed in the chemical industry [11]. A large number of studies have been performed on optimization of the basic structural parameters of such apparatus, but further increase of their operating efficiency requires adequate models of the gas-dynamic processes occurring in the power separation chamber of the vortex tube.

Figure 1 shows a diagram of the laboratory setup used to study the character of the gas flows in the region of the swirled flow near the axis. To determine the gradient of the static pressure in the direction of the axis a probe ($d_p = 8$ mm) was placed coaxially into the power separation chamber ($d_c = 40$ mm) of the vortex tube. Two openings ($d = 0.5$ mm), which were connected with a U-shaped liquid manometer, were made in the probe. The pressure gradient was calculated from the indications of the manometer and the distance between the openings (11.5 mm). The coordinates of the probe (Figs. 2 and 3) are the coordinates of the opening on the left (Fig. 1).

The construction of the probe made it possible to study the pressure gradient at any points at a level of 0.2 of the radius of the power separation chamber. The form and size of the measuring part of the probe were chosen in accordance with the recommendations of [2]. Judging from the operating efficiency of the vortex tube and the stability of the manometer indications, the probe did not significantly disturb the power separation process. The insignificant effect of the probe on the efficiency of the vortex tube was manifested only when the probe entered the diaphragm channel of the SSU.

Investigation of pressure gradient field rather than the pressure field made it possible to employ a water-filled U-shaped manometer. This increased by an order of magnitude the sensitivity of the regulating apparatus compared with standard pressure measurements in a flow with the help of membrane or mercury manometers.

In a swirled flow at a level of $0.2R$ both positive and negative pressure gradients occur. The former give rise to motion of gas in the diaphragm, while the latter impede it. The gradient field exhibits a definite spatial periodicity (Fig. 2). Its character depends on the relative fraction of the cooled flow μ . If the periodicity is measured by the distance between the corresponding extreme values of the gradient, then three characteristic distances can be separated: $h_1 = (25 \pm 5)$ mm, $h_2 = (50 \pm 10)$ mm, $h_3 = 100 \dots 120$ mm, reflecting the internal structure of the flows with a pitch of the spiral channels with the SSU equal to 40 mm. As a rule, these distances assume maximum values for low values of μ and minimum values for high values of μ . The periodicity and change in the sign of the pressure gradient are caused by the jetlike, spiral flows of the main flow in the zone near the axis. This is confirmed by studies of the pressure gradient fields in different azimuthal directions and local deviations of the flow of a small jet of oil on the surface of the probe in the direction of rotation of the main flow.

Comparison of the pitch of the spiral formed by the jet flows on the surface of the chamber and in the zone near the axis shows that we are dealing with a radially extended jet. The condition of equilibrium for an element of the jet has the form

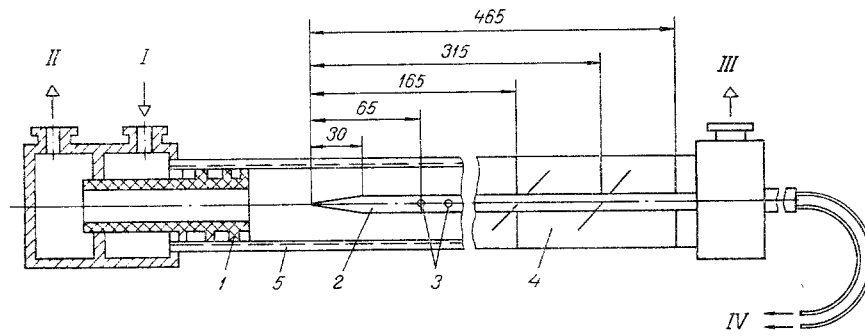

Fig. 1. Diagram of the setup used to study the static pressure gradient field in the swirled flow in the region near the axis: 1) SSU; 2) probe; 3) pressure measurement points; 4) supports for centering the probe; 5) glass power separation chamber; I) compressed gas; II) cooled flow; III) heated flow; IV) to manometer.

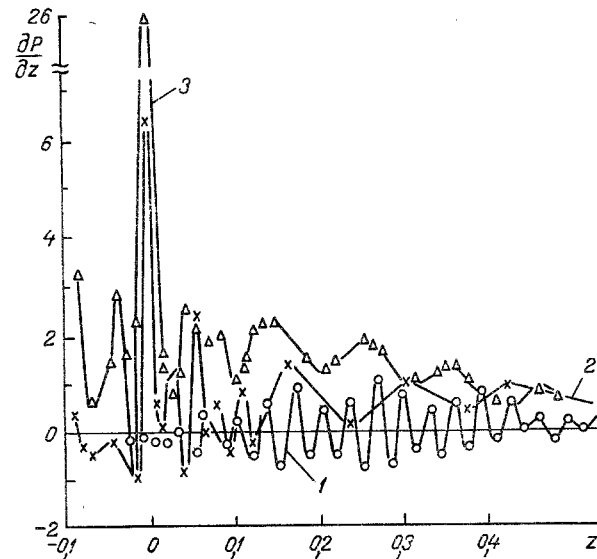

Fig. 2. Variation of the gradient of the static pressure along the vortex tube for $\pi = 2.7$: 1) $\mu = 0$, 2) 0.34, and 3) 1.0, z , mm; $\partial P/\partial z$, Pa/m.

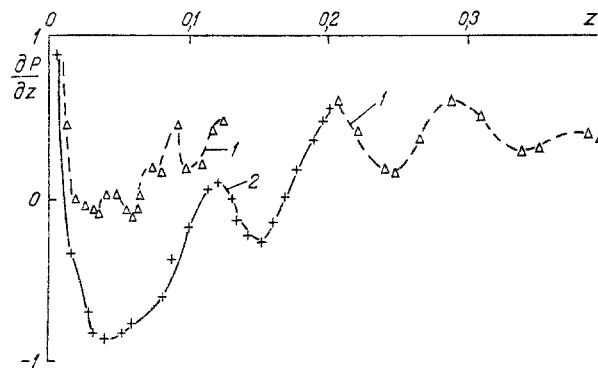

Fig. 3. Change in the minimum values of the pressure gradient in the main jets of a two-channel SSU for $\pi = 2.7$ and $\mu = 0.34$: 1, 2) jet numbers.

$$\frac{\partial P}{\partial r} = \rho \frac{V^2 \varphi}{r} \quad (1)$$

Using Eq. (1), the relative length of a loop (relative quantities are determined with respect to the corresponding parameters at the periphery of the jet) of the jet flow at the level of interest can be related with the flow parameter. For this we assume that the gas is ideal, its expansion in the radial direction is adiabatic, and the pitch of the spiral and velocity of the gas are constant over the height of the jet. Taking this into account, we have

$$\bar{l} = e^{-\beta}, \quad (2)$$

where

$$\beta = \frac{R' k T_{\text{per}}}{M V^2 (k-1)} \left(1 - \frac{k-1}{\bar{P}^k}\right). \quad (3)$$

As the relative fraction of the cooled flow increases, the pressure becomes equalized over the cross section of the tube, the relative pressure P and the length of a loop \bar{l} in the layers of the jet near the axis increase, and the value of β decreases. This means that the height of the jet decreases and the structure of the swirled flow in the region near the axis changes (see Fig. 2). As μ increases the structure with the characteristic distance h_1 changes gradually into a structure with the parameter h_2 , which for large values of μ degenerates into a larger, spiral structure with the parameter h_3 .

The existence of spiral jet structures with the parameter h_1 indicates that both jets injected into the chamber reach the region near the axis. The transition to a structure with the parameter h_2 indicates that one of the jets vanishes at the level 0.2R.

The fact that the jet vanishes from the level 0.2R was discovered experimentally by direct observation of the jet. If the jet is located above the second opening of the probe, then the pressure gradient determined is negative or has a minimum positive value. The behavior of minimum pressure gradients for each jet with $\mu = 0.34$ is shown in Fig. 3. At a distance of three units at the level 0.2R two jet flows are observed, and in the interval from three to five units one jet is observed. The vanishing of a jet from the 0.2R level changes the structure of the flow in the region near the axis (see Fig. 2).

The more powerful second jet also vanishes at a distance of five units from the nozzle inlet (curve 2, Fig. 3). Its vanishing gives rise to the appearance of another jet at diametrically opposite points at the level under study and with the same pressure gradient. At the eleventh unit in the power separation chamber no jets at the level 0.2R were recorded, while two jets are once again observed at the twelfth unit. This behavior of the jets indicates that they are interrelated and that there exists a single foundations or substrate through which the jets exchange energy and mass.

It follows from the experiments that the swirled flow in a vortex tube is a self-regulated system. The mass transfer required for the system to be stable can occur in the diaphragmed zone. This leads to the fact that a distance of 0.5 units the intensities of the jets are significantly different (Fig. 3).

The complicated dynamics and interaction of the jets are confirmed by the results of measurements of pressure gradients in different azimuthal directions. Gradients at diametrically opposite points vary in antiphase. Such strict synchronization of the changes in the pressure gradients, like their periodicity, indicates that the large spiral structure is of a wave nature and confirms the hypothesis that the jets have a single base or substrate. The velocity of the wave traveling along the jet relative to the vortex tube is higher than the velocity of the jet. For this reason, the disturbed state of the jet describes a spiral line with a pitch h_3 larger than the pitch of the jet h_2 .

Gradients determined by the jet flows are an order of magnitude larger than the mean value of the gradient calculated from the pressure drop P_x and P_G at the ends of the vortex tube. Therefore they determine the flow of gas in the counterflow. The jets of the main flow force the counterflowing gas to flow in the space between the jets. This flow rotates in the opposite direction. This fact is confirmed by the rotation of a small jet of oil at the probe in a direction opposite to the rotation of the main flow. This rotation for $\mu \leq \mu_{\text{op}}$ is observed on the section 2...2.5 units at the nozzle. The action of the counter-

flow explains the powerful opposite rotation of a thin-walled, hollow, cylindrical insert ($d = 30$ mm, $l = 100$ mm, $d_c = 40$ mm) at markers 110...130 mm from the nozzle section.

Comparison of the cutoffs of the pressure gradient field in different azimuthal directions and direct observations of jets (Fig. 3) show that the jets of the main flow and of the counterflow undergo radial oscillations. Therefore with a probe one studies the static pressure deformed by the dynamic pressure owing to the radial velocity of the gas.

When the jet moves near the axis the angular velocity of its elements increase, the pitch of the spiral decreases somewhat, and the tangential velocity and the angular momentum (L_T) increase. The angular momentum of the counterflow L_{cf} also increases in accordance with the law of conservation of angular momentum ($L_T - L_{cf} = \text{const}$). After the elements of the jet leave the region of strongest interaction they will have excess angular momentum, which is what causes them to move toward the periphery. This is how the intercoupled oscillations of the jets, which have a self-excited character, are generated. The self-excited oscillations are the source of waves traveling along the jet and giving rise to a spiral, jet structure with parameter h_3 . The self-excited oscillations and waves occur in all operating states of the vortex tube. For this reason structures with the parameter h_3 are observed for all values of μ (see Fig. 2).

Increasing the relative fraction of the cold flow decreases the pitch of the spiral of the jets in the main flow. In addition, the flux of mechanical work from the main flow into the backward jet decreases owing to the increase in the rigidity of the backward jet. For this reason, for large μ we have faster jet currents in the main flow. This increases the pressure gradients as μ increases (Fig. 2) and it increases the tangential [3] and angular velocities [4].

The stopping of the gas in the backward flow on the surface of the nozzle section of the SSU and the increase in the velocity of the cooled flow in the plane of the diaphragm, when the probe occupies part of the cross section of the diaphragm, are responsible for the sharp increase in the pressure gradient in the zone near the diaphragm (Figs. 2 and 3). In this case the first opening of the probe is located in the diaphragm channel, while the second opening extends by 3...4 mm into the power separation chamber. The parasitic flow near the diaphragm, observed in [5], is obviously part of the backward gas flow, stopped on the surface of the diaphragm.

As the degree of expansion of the gas π increases, the character of the oscillations of the jets changes somewhat. The highest value of the pressure gradient is located farther from the nozzle inlet for $\pi = 3$ ($\mu = \mu_{op}$) than for $\pi = 2$. A spiral jet structure has been observed in swirled flows, generated by a swirling unit, like in the case of SSU.

Investigations of the changes in the static pressure gradient in the region near the axis of a cylindrical vortex tube showed the following. The jet flow is caused by the thermo- and gas-dynamic properties of the gas flows. The spiral structure established by the swirling unit is preserved in the starting flow, but its pitch changes. The jet of the main radial flow does not always reach the axis of the tube. The structure and parameters of the jets in the main and backward flows depend on the operating regime, the degree of expansion, and the coordinates relative to the nozzle inlet. Restructuring of the main flow occurs as a result of the action of the backward jets, self-excited oscillations, and wave processes. These processes determine the penetration depth of the main flow, in the form of jets, into the region near the axis. The jets in the main flow at the periphery are coupled with one another and exchange energy and mass. Part of the gas in the backward flow flows along the innerjet space in the main flow. The static pressure gradient, owing to the jet character of the flow, is an order of magnitude higher than the mean value of the pressure gradient in the vortex tube.

NOTATION

d_c , diameter of the vortex tube (power separation chamber); d_p , diameter of the probe; d , diameter of the measuring openings; R , inner radius of the vortex tube; μ , the relative fraction of the cold flow (G_c/G_{total}), or the operating regime; h , pitch of the spiral; P , pressure; \bar{P} , relative pressure; V , velocity of the jet; ρ , density; l , length of a loop of the jet; e , base of the natural logarithm; R' , universal gas constant; k , adiabatic index; M , molar mass of the gas; T_{per} temperature at the periphery of the jet; P_h and P_c , pressure at the hot and cold ends of the tube; L_T , angular momentum; π , degree of expansion of the gas flow (P_1/P_c); and r , instantaneous radius.

LITERATURE CITED

1. R. Kh. Mukhutdinov, "Vortex effect and its commercial applications," in: Proceedings of the 3rd All-Union Scientific-Technical Conference, Kuibyshev (1981), pp. 143-146.
2. A. N. Petunin, Procedure and Instrumentation for Measuring the Parameters of Gas Flows [in Russian], Moscow (1972).
3. A. D. Suslov et al., Vortex Apparatus [in Russian], Moscow (1985).
4. Yu. T. Portnov, "Investigation of the aerodynamics and heat transfer of a vortex of diaphragmed tube with a spiral swirling unit," Candidate's Dissertation in Engineering Sciences, Kazan (1974).
5. A. P. Merkulov, Vortex Effect and Its Application in Engineering [in Russian], Moscow (1969).

TURBULENT HEAT AND MASS TRANSFER IN CONFINED TWISTED FLOWS

V. I. Terekhov

UDC 536.24:532.526

Results are presented from a study of aerodynamics and heat and mass transfer in turbulent rotating flows. An examination is made of flow in the initial section of a pipe, flows with peripheral twisting, and stabilization of an axial jet by a twisted flow in a swirl chamber.

Vortex flows are widely used in different areas of modern technology. As a rule, twisting of a flow is connected with a need to intensify transport processes in power plants or chemical processing equipment. However, in several cases, twisting can also be used to reduce heat and mass transfer - such as in the stabilization of plasma jets and flames.

Many studies have already examined twisted flows. Most of these studies have investigated general laws governing the flow, laminar flow, and flow stability. Most investigations of turbulent transport have been conducted for fully developed pipe flow.

Vortex flows are characterized by wide variety even in regard to the qualitative flow pattern, which is determined mainly by the geometric and discharge characteristics. The many methods available for twisting a flow - swirl vanes at the inlet of a channel, tangential gas feed, belt- and screw-type swirlers, etc. - seriously complicates analysis and generalization of experimental results. The most common approach here has been to generalize test data in relation to the initial geometric and discharge conditions of the specific equipment used in the experiment. A detailed examination of questions related to heat transfer in channels with the use of different methods of flow twisting is presented in [1].

The studies [2, 3] and certain later investigations used the so-called principle of streamline rectification to calculate turbulent heat and mass transfer and friction. This approach involves converting relations for the heat and mass transfer coefficients and friction coefficient in a plane boundary layer to the case of a twisted flow, assuming that the twisted flow is examined along the helical streamline with the corresponding parameters on the external boundary of the boundary layer. Here, in essence, the investigator is considering the intensification of heat transfer and friction which occurs only as a result of an increase in the velocity vector on the external boundary of the boundary layer and the longitudinal coordinate. It should be noted that allowing for only these factors does not always permit generalization of the available empirical data.

At the same time, it is known that the body forces due to curvature of streamlines can also affect the turbulence characteristics of a flow. It follows from the theory of flows with curvilinear streamlines [4-6] that turbulence is suppressed in a boundary layer on a

Institute of Thermophysics, Siberian Branch, Academy of Sciences of the USSR, Novosibirsk. Translated from *Inzhenerno-Fizicheskii Zhurnal*, Vol. 53, No. 6, December, 1987. Original article submitted June 17, 1986.